

NOVUM

Redefining refrigeration

ARAN RANGE Technical Specifications



The ARAN RANGE

The DOE approved Aran range combines exceptional panoramic product visibility, superior product facing combined with technical innovations like LED lighting, automatic defrost and dual refrigeration system with thermally sealed curved glass lids to reduce energy consumption and improve the customer experience. The design concept was simple - people buy what they see, so let's give the best possible visibility.

The unique curved glass front, the cornerstone of the Novum Aran range, offers an unequalled view into the cabinet leading to increased impulse sales.



**DOE
approved**



**27%
Higher
visibility**

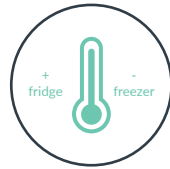

**Universal
Freezer &
Chiller**



***35%
Lower on
Energy Bills**

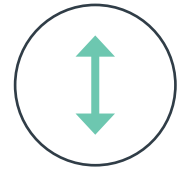

**Lift up or
Sliding lids
Save on
Energy**

*when compared to remote refrigeration



The Novum ARAN RANGE

is guaranteed to enhance the image of your store and improve your customer shopping experience. It is a versatile cabinet that can be used as a stand alone unit, as part of a line-up, back to back or as part of a full island and is available with either sliding lids or a full, lift-up lid.

Technical Specification

Aran Range	Model	806L	706L
Technical Data			
Gross content	cu. ft.	32.4	22
Net Content according to EN 23953	cu. ft.	26.2	20
Total Display Area (TDA)	sq. ft.	15.5	12.9
Classification according to EN 23953		3L1	3L1
Ambient Temperature Range	°F	+61 to +77	+61 to +77
Inner Temperature Range	°F	0 to -13	0 to -13
Sound Pressure at 1m Distance	dB(A)	43 .3	43 .3
Electrical Data			
Nominal Voltage / Frequency	V / Hz	110-120 / 60	110-120 / 60
Nominal Power Cabinet	w	700	700
Nominal Power LED Light	w	24	24
Nominal Current	A	7	7
Fuse Protection	A	15	15
Energy consumption (at 77°F)	kWh/24h	7.8	8.6
Length of Power Supply Cord	inches	78.7	78.7
Refrigeration Data			
Refrigerant	Type	R290	R290
Gas Charge	oz	3.5 X 2	3.5 X 2
Maximum Operating Pressure	PSI	435	435
Maximum Heat Output	W/h (Btu/h)	1130 (3853)	1130 (3853)
Dimensions			
Length Outside/ Inside	inches	86.8 / 81.1	75.0 / 69.3
Depth Outside/ Inside	inches	32 .7 / 27	32.7 / 27
Front Access Height Outside / Inside	inches	36.5 / 25.6	36.5 / 25.6
Stacking Height at the Front / Back	inches	23.6 / 25.6	23.6 / 25 .6
Weight			
Net Weight (excl. packaging, incl. internal accessories)	lbs	421	412
Gross Weight (incl. packaging & internal accessories)	lbs	494	485

Dimensions Aran 706L

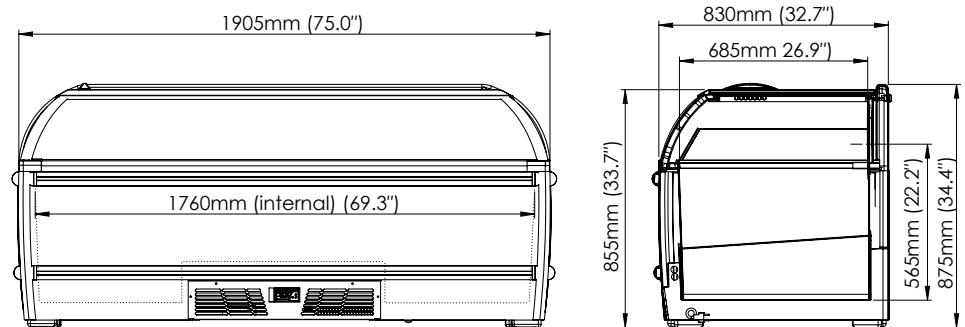

Dimensions Aran 806L

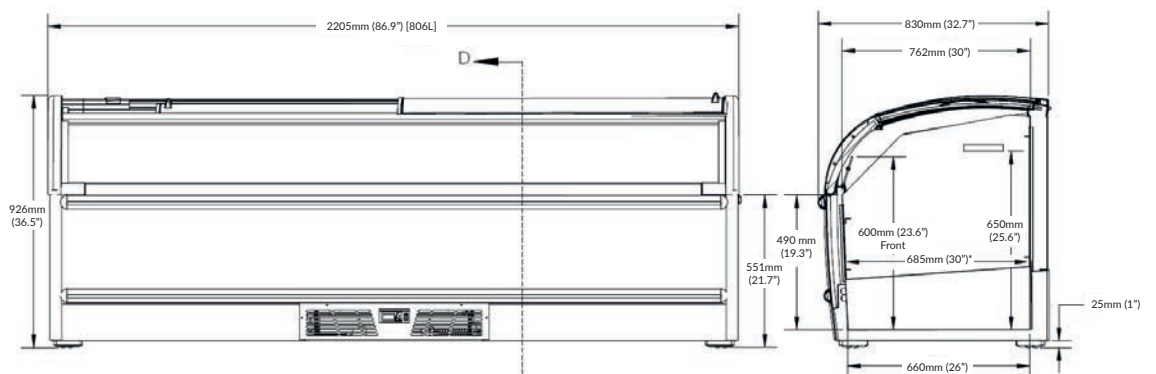

*Including Buffers

Novum USA

7405 Graham Road
Suite B
Fairburn
GA 30213
Phone: (678) 787-0755

www.novumusa.com

NOVUM
Redefining refrigeration

